

# Wood Cabin Assembly Manual

## Parts List

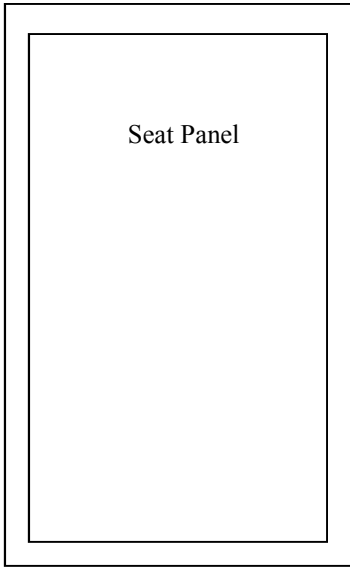

**The Wood Surface Faces Outside,  
The Foil Faces Inside**

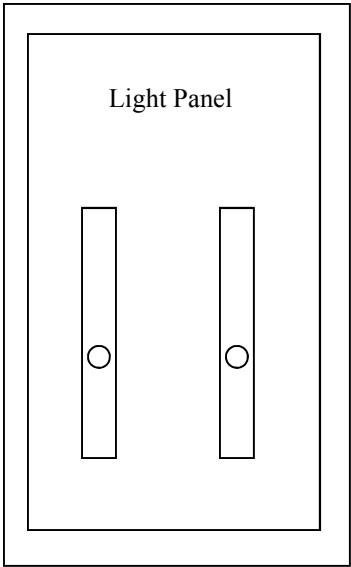
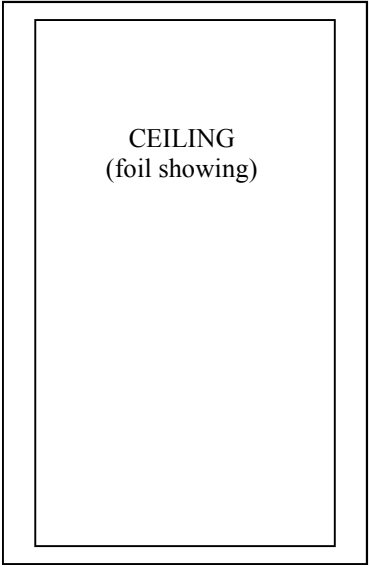
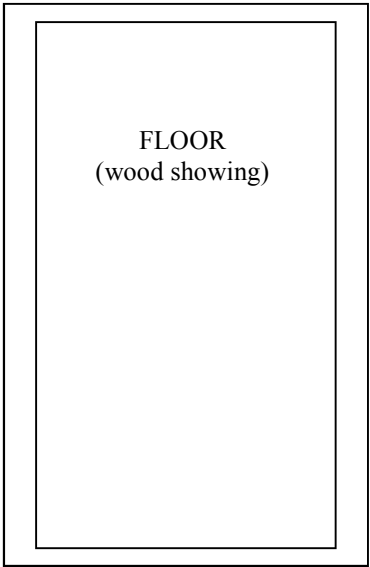
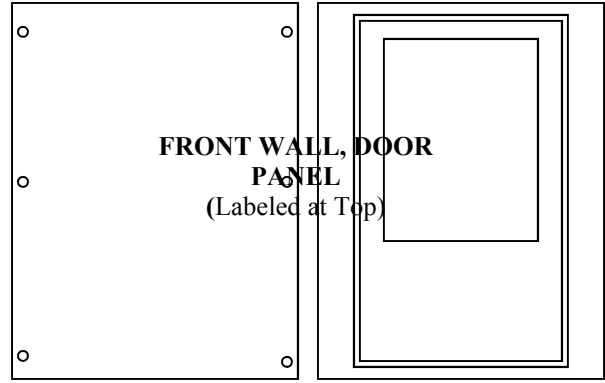
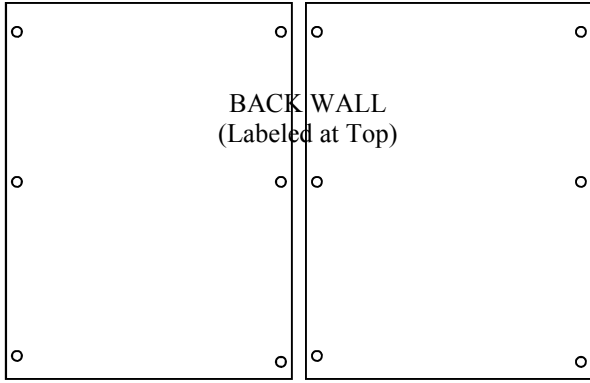

\*\*\*Be Extremely Careful When Handling the Door



JOINING STRIPS  
(Labeled on Back)

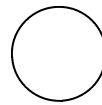

BULBS (8)

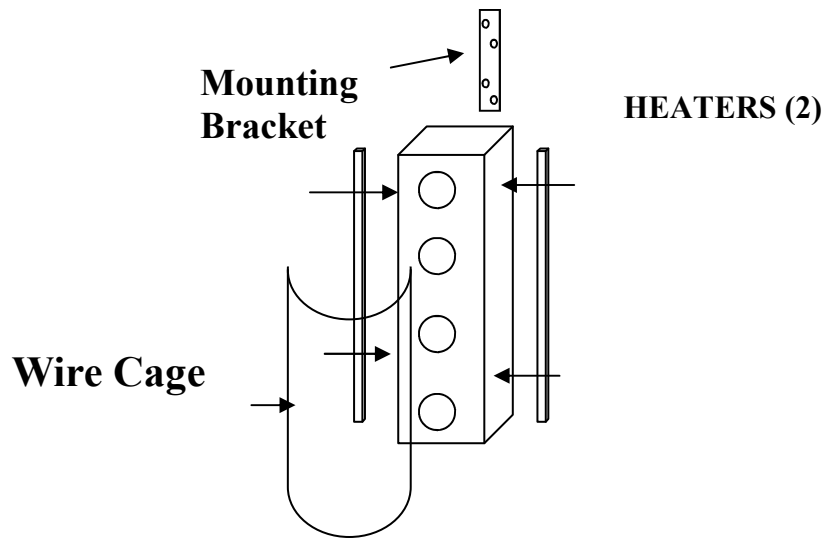

## Floor Detail

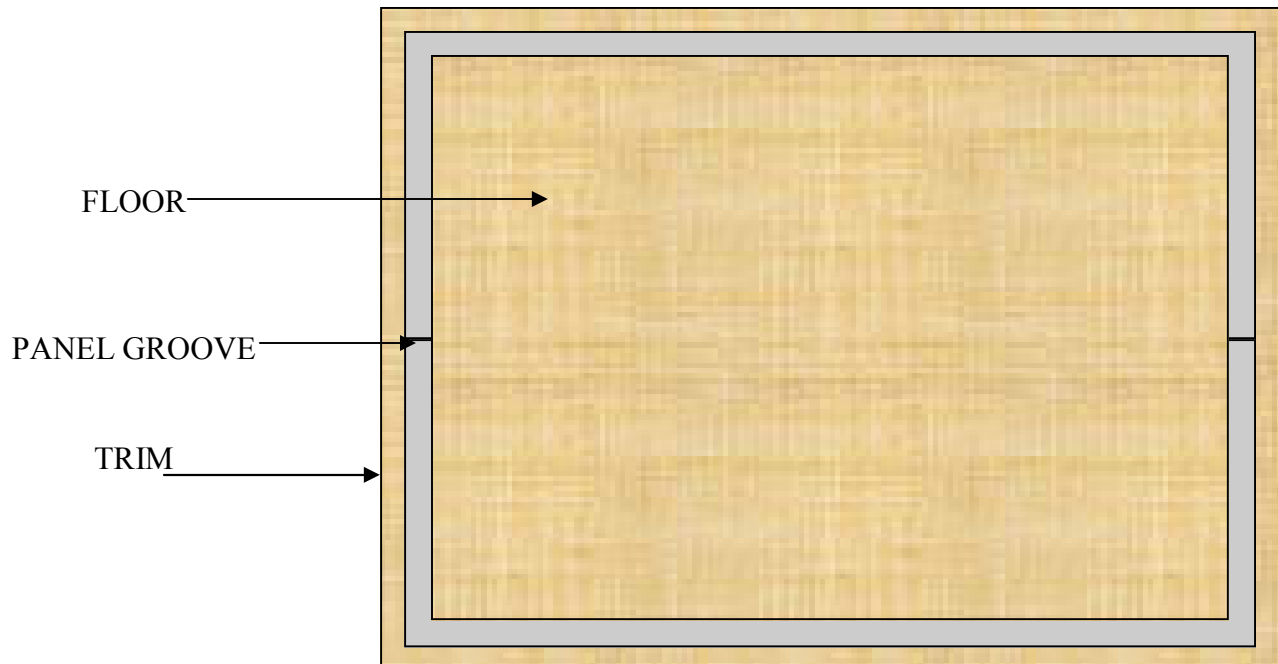

The gray area represents a groove that sits between the floor and the trim. The wall sections stand in this groove. The groove is 1 inch wide to allow for expansion and contraction of the wall panels

The ceiling is placed on top of the walls so that the wall panels fit into the ceiling groove.

\*\*\*Please note that the ceiling is the piece with the Foil. The Floor has no foil.

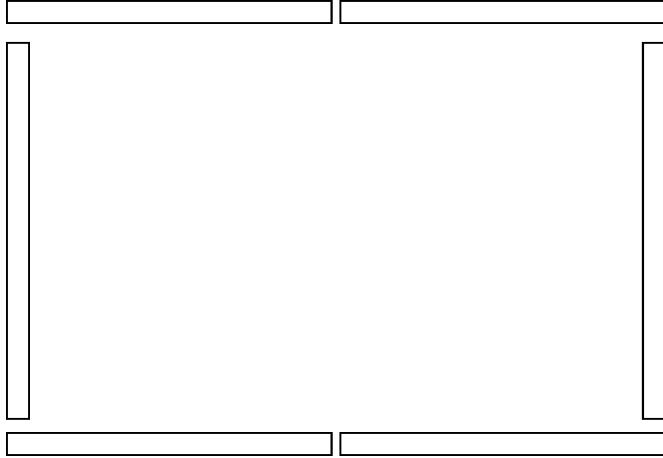

### WALL ASSEMBLY OVERVIEW

This is the general assembly structure of the sauna walls. Note the corner assembly where the short sides are sandwiched between the long sides.

All Panels have labels on top indicating the top. The front is the wood and the foil faces inward.

Assembly begins with a corner for stability. Place each panel into the floor groove and have 1 person hold the panels in position while a second person screws the corner together with (4) 1.5 inch “panel screws”

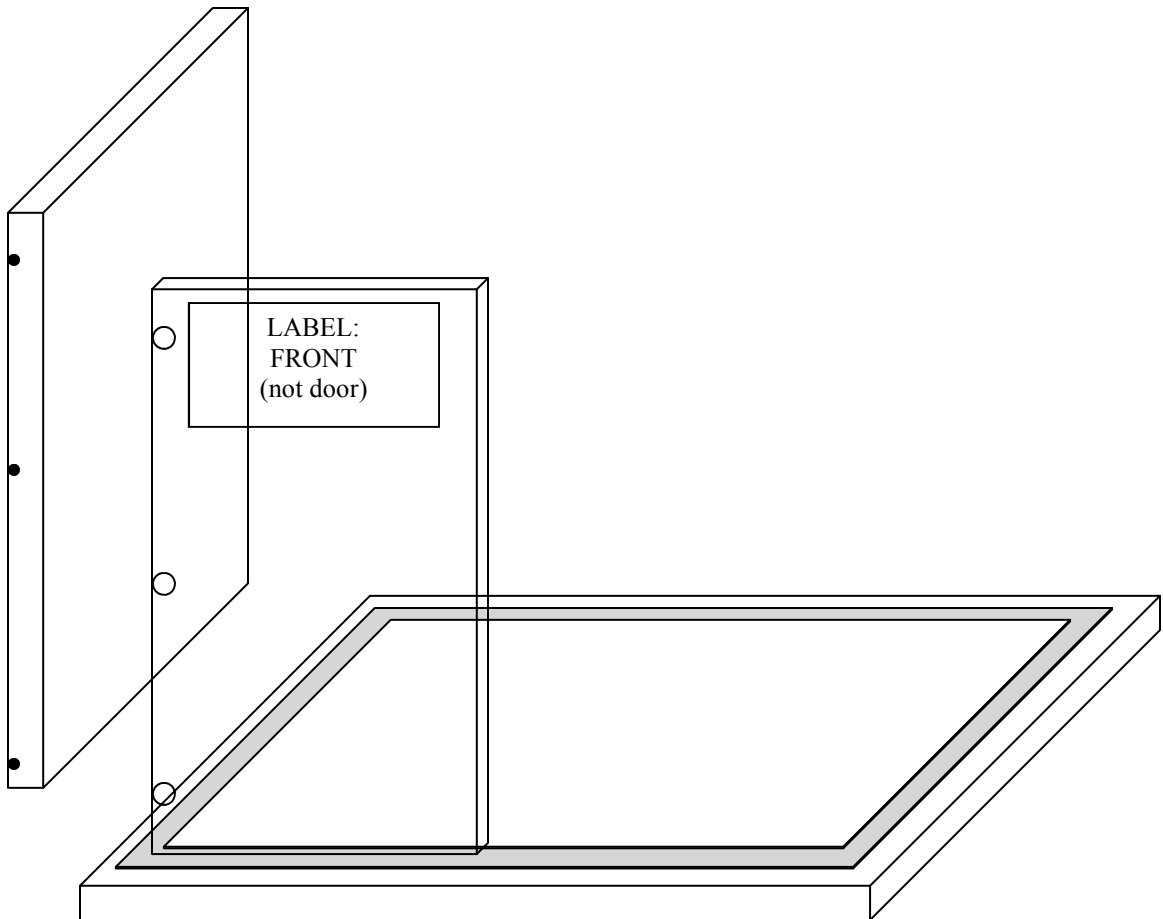

Align corner and screw fasten 3 panel screws

After the corner is fastened, add joining strip.

The Strips are labeled on the back, at the top side and tells you which end is up.

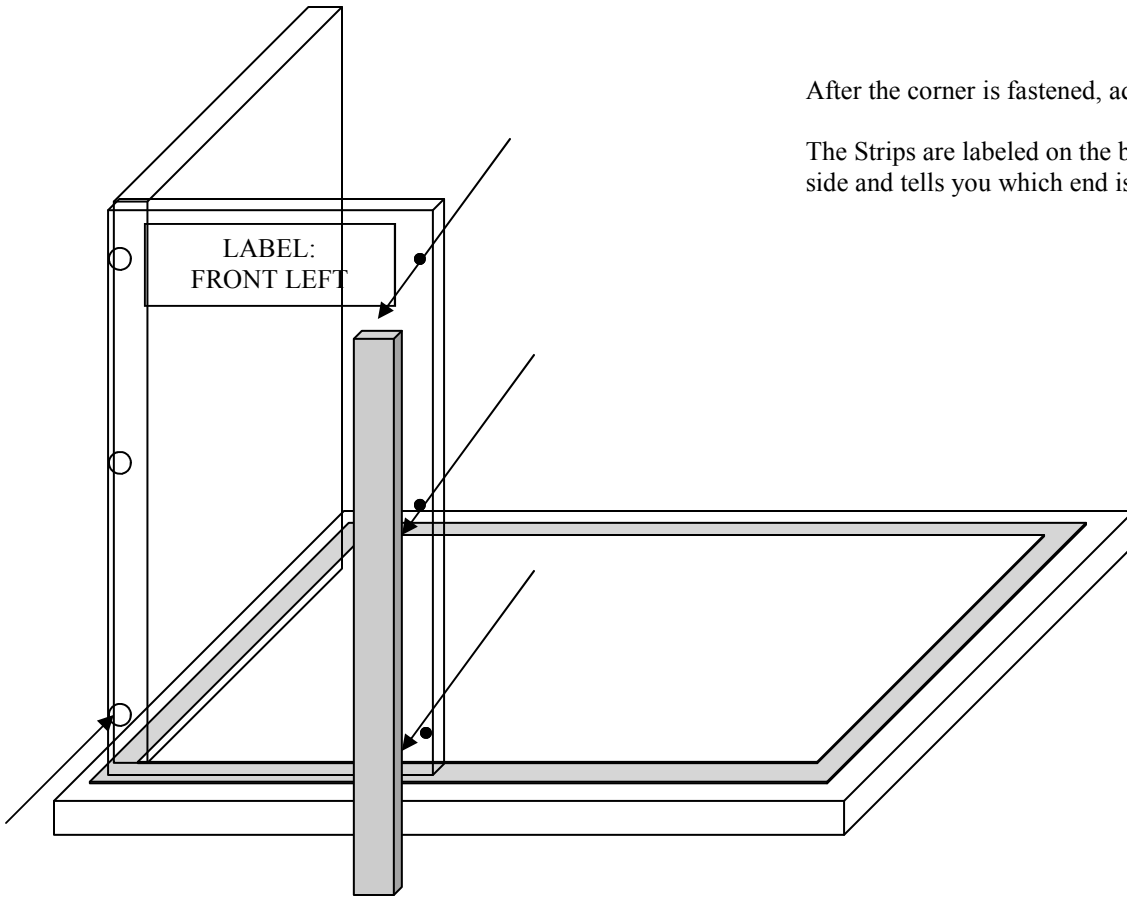

#### Joining Strip Instruction:

The joining strip hold the panel seams together. They rest on the outside of the sauna, and are screwed on from the inside of the sauna

To attach: check label and hold the strip on the front of the sauna while fastening screws through holes, into pre-drilled holes on back of strip. Hold second panel in place while attaching the other side of the joining strip to the second panel

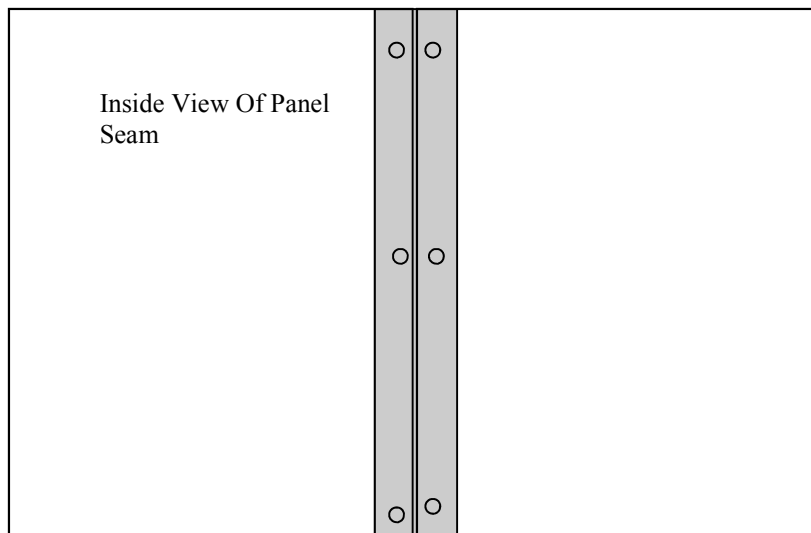

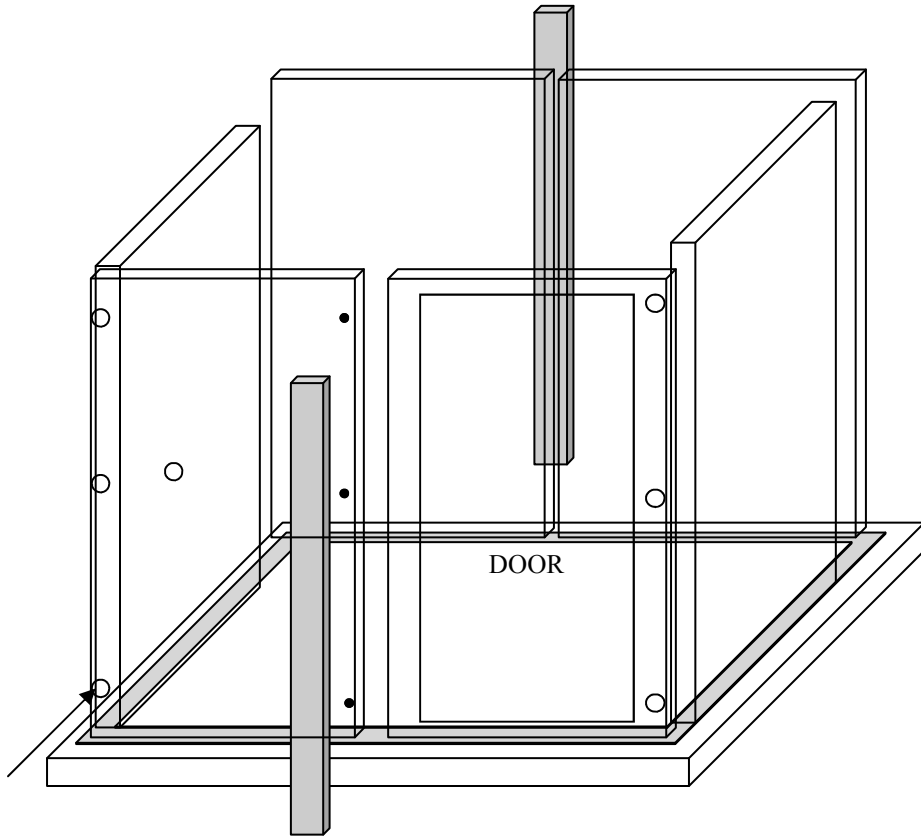

Continue to work your way around the sauna, placing panel screws in the corners, and fastening the joining strips.

\*\*\*The door panel has 2 protective screws through the handle holes to prevent the door from swinging open. Remove this screw AFTER placing the door panel in place. Be very careful when handling the door panel so the door does not swing open.

### Assemble and Hang the Lights

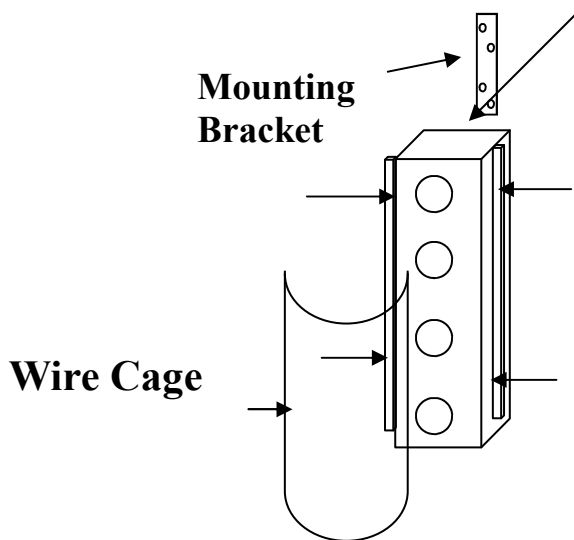

-The wire cages rests inside a groove on the side of the heater. Remove Screws where the arrows show and slide the edge of the wire cage into the groove. Replace screws.

-Fasten the mounting bracket on the back of the heater with mounting screws and into predrilled holes on the top rear side.

-Slide power cord through back wall hole and hang the light through 2 small predrilled holes on back wall

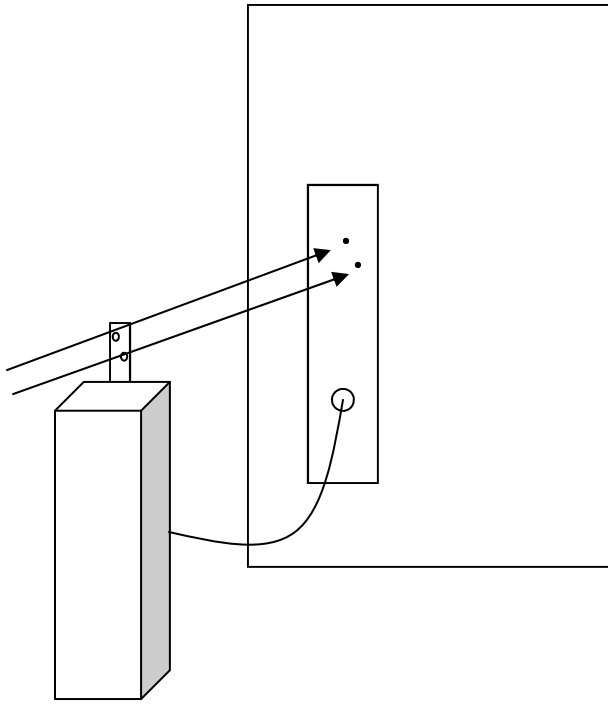

Hang Lights on back wall with screws provided with mounting brackets. Guide through pre-drilled holes into back of wall.

The green power cord runs through the back holes.

## Add Ceiling

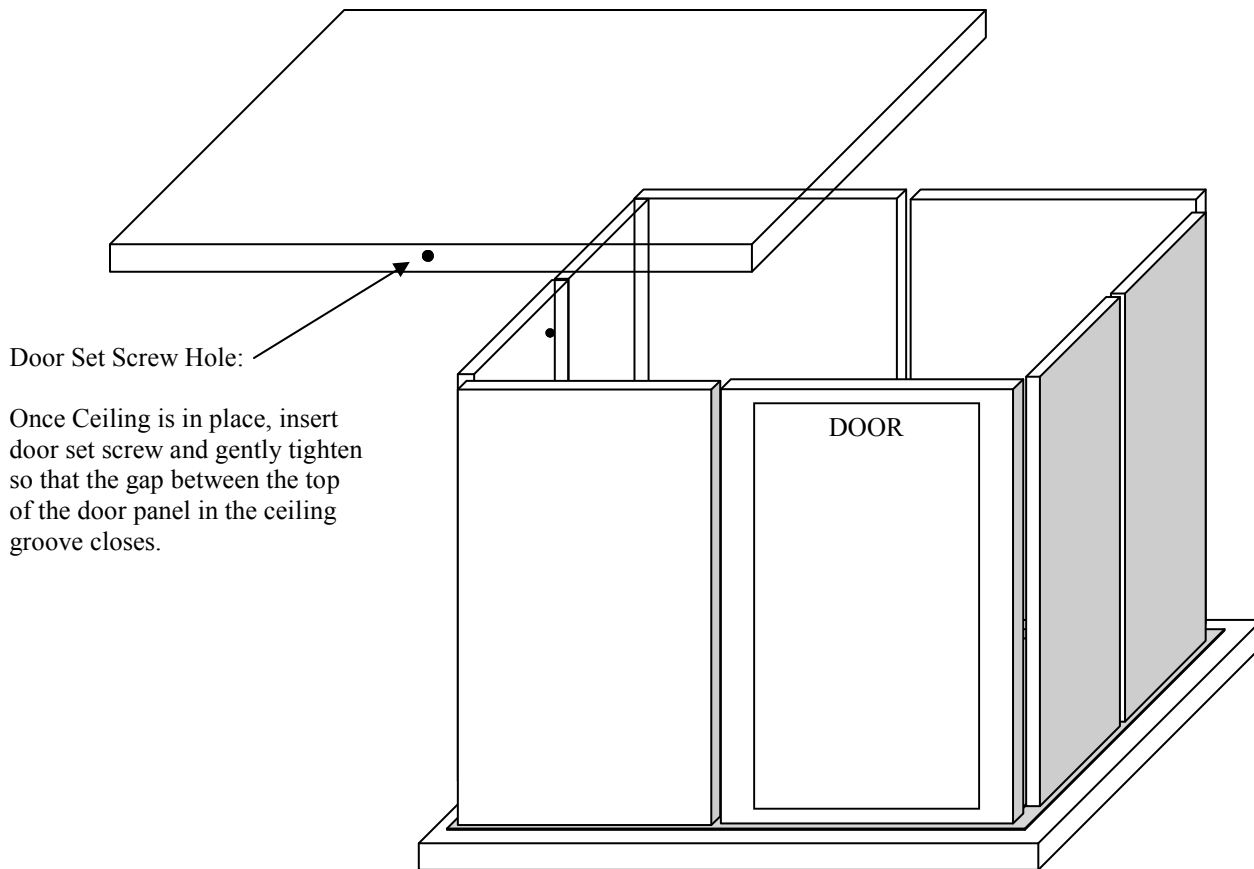

Carefully, with two people, place the ceiling piece on .

Make sure the wall panels fit in the grooves and the ceiling will just drop into place. This is a 2 person job.

## Add Door Hardware:

- Remove safety screws in front door handle hole.
- Attach door handle with 2 screws through pre-drilled holes on back of door.
- Door Magnet is pre installed.

## To Use:

**-Plug both cords in.**

**-On the left side of the heater are the controls. There is a timer at the top and an on/off switch that controls the 4th bulb on each heater. You can run the sauna with 6,7 or 8 bulbs at once. I highly recommend that you begin sauna use with only 6 bulbs at one.**

**-To turn on, push the timer buttons and scroll through the time settings to the desired setting. Flip the lower switch to on/off for desired heat setting.**

**-Preheating is not necessary but will make the sauna hotter if you prefer it.**

**-Enter the sauna. When sitting on the stools, rotate 90 degrees every 4-10 minutes, and make sure all parts of your body receive the light. It is not recommended to have one side face the light for more than 10 minutes at a time.**

**-To protect the wood, please place a towel on the floor and stool to absorb sweat.**

**-If you are not used to using a sauna, start with short sessions of 10-15 minutes. Gradually build your time to 30 minutes.**

**-Make sure to drink lots of water and to replace electrolytes.**

**-It is not recommended to bring water inside the sauna. This is to prevent spills on the untreated wood to and to prevent accidental contact with the hot bulbs.**

**-Never touch hot bulbs in use.**

